



Vacuum Pumps and Compressors for Filter Applications



NASH Vacuum Pumps & Compressors for Filter Applications

Industry Workhorses

Nash liquid ring vacuum pumps and compressors produced by Gardner Denver Nash have been used in many industrial applications for more than 100 years. They are known as tireless workhorses, designed to stand up to the rigorous, nonstop demands of the harshest industrial environments. Built better than industry standards, NASH pumps are known for their reliability.

Nash pumps are manufactured to ISO 9001:2000 standards and are Category 2 ATEX compliant. Nash's commitment to excellence and customer service extends from manufacturing and installation to technical assistance and beyond. Service and distribution centers are located throughout the world, offering quality service and support for Nash products.

NASH Features	User Benefits
Ability to handle process carryover or recycled gases	Increased operating efficiency and reduced operating costs
Long design life	Highest reliability
No internal lubrication required	Less maintenance required; less downtime
No metal-to-metal contact	Simple operation; wear-free performance
Cool Running	Incoming vapor is condensed. Smaller, less costly equipment can be selected
Only one moving part	Simple and trouble-free operation
Proven energy efficient design	Lower operating costs, year after year
Over a century of engineering and application experience	Optimal system design for all filtration requirements

Vacuum Pump Capacity Range

actual m³/hr • ft³/min

Vectra & SC Range

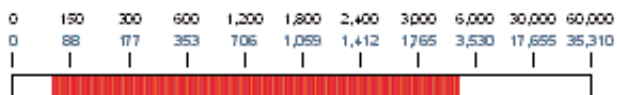

Vacuum to 31 mbar A • 29+” HgV

- Vectra Series Ductile Iron, Stainless Steel
- SC Series Ductile Iron, Stainless Steel

2BE, P2620, 904 & CL Range

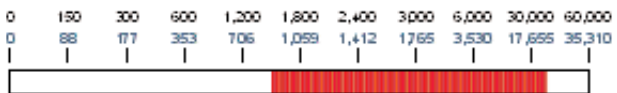

Vacuum to 200 mbar A • 24” HgV

- 2BE Series Cast Iron, Stainless Steel
- 904 Series Cast Iron, Stainless Steel
- CL Series Cast Iron, Stainless Steel

Compressor Capacity Range

N m³/hr • SCFM

Compressor Range

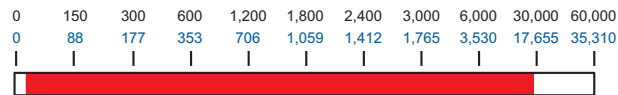

Pressure to 1.5 bar abs - 22 PSIG

- Vectra Series Ductile Iron, Stainless Steel
- SC Series Ductile Iron, Stainless Steel
- CL Series Cast Iron, Stainless Steel
- 2BE Series Cast Iron, Stainless Steel
- 904 Series Cast Iron, Stainless Steel

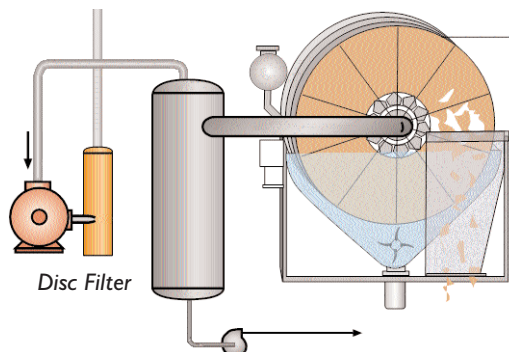

NASH Vacuum Pumps & Compressors for Filter Applications

Application	Drum	Drum Precoat	Disc	Horiz. Belt	Table	Tilting Pan
Chemical processing	x	x	x	x	x	x
Catalysts				x		
Pharmaceuticals	x	x				
Mining & mineral processing	x			x	x	
Alumina (red mud)	x	x				
Aluminum Hydrate			x			x
Aluminum seed filter			x			
Coal			x	x		
Copper concentrate			x			
Graphite				x		
Gypsum	x					
Iron ore (hematite, taconite)			x			
Kaolin Clay	x					
Metal Hydroxide waste	x					
Molybdenum			x			
Oily and chemical wastes		x				
Phosphate					x	
Phosphoric Acid				x		x
Polishing		x				
Potash				x		
Pyrite flotation concentrates			x			
Tank wash		x				
Titanium Dioxide (ilmenite)	x			x		

Brochure photos courtesy of: Andritz AG, Delkor, Dorr Oliver Eimco, Larox, RPA, WesTech



Disc Filter

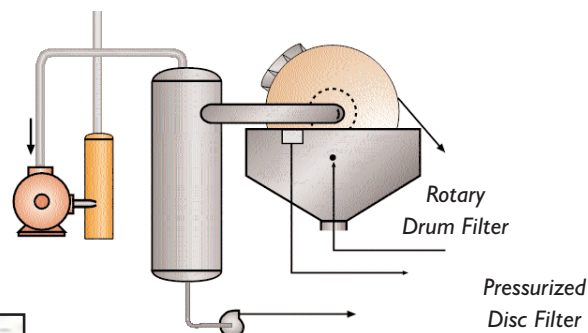

Pressurized Disc Filter

Table Filter



Tilting Pan Filter

NASH Vacuum Pumps & Compressors for Filter Applications

Application	Drum	Drum Precoat	Disc	Horiz. Belt	Tray	Tilting Pan
Agricultural products				X		
Corn	X			X		
Corn syrup		X				
Food processing	X	X	X			
Poultry		X				
Sugar cane					X	
Flue Gas Desulfurization				X		
Industrial water treatment	X			X		
Dewatering very dense or granular materials					X	
Pulp & Paper manufacturing	X	X	X			
Lime mud		X				
Paper recausticizing process		X	X		X	
Pulp manufacturing	X					X

Rotary Drum Filter



Horizontal Belt Filter



Tray Filter

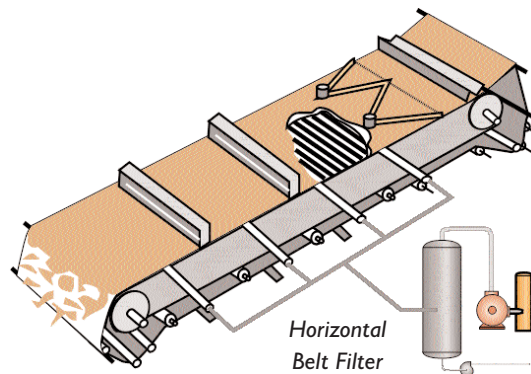

Horizontal Belt Filters

Disc Filter

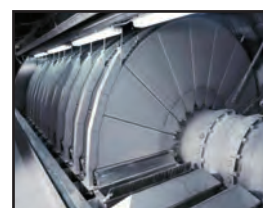

NASH Vacuum Pumps & Compressors for Filter Applications

Filtration

Filtration is the process of separating solid particles from a liquid slurry. All forms of filtration require a pressure differential to make the liquid pass through a porous filter medium/membrane. Some processes apply a vacuum to the underside of the filter medium in order to draw the liquid through. Other processes apply a compressed gas to the slurry side of the filter medium to force the liquid through.

For every application, the solid's particle size, quantity and properties have to be carefully assessed to decide what type of filter will be most suitable and what filter medium should be used. Various filtration techniques have been developed to meet the requirements of many different industrial applications.

In every filtration application, a Nash liquid ring vacuum pump or compressor can reduce operating costs and minimize downtime.

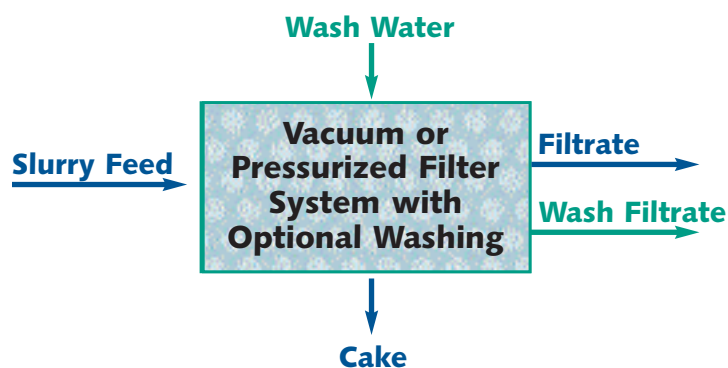

Drum Filter Vacuum System

Some Companies Offer Service...Nash Specializes in Service

Filter applications can be hard on pumps and compressors. Nash's service organization is ready to provide support keeping your process running smoothly and efficiently and to avoid extensive equipment downtime.

We have the capability to provide turnkey service for installation, startup, preventive maintenance and troubleshooting your vacuum or compressor system. Our facilities are fully equipped with material handling equipment, tooling, fixtures and special machines to handle rebuilding and overhauling pumps, compressors, and engineered systems.

A Nash Liquid Ring Filtration System - BUILT TO LAST

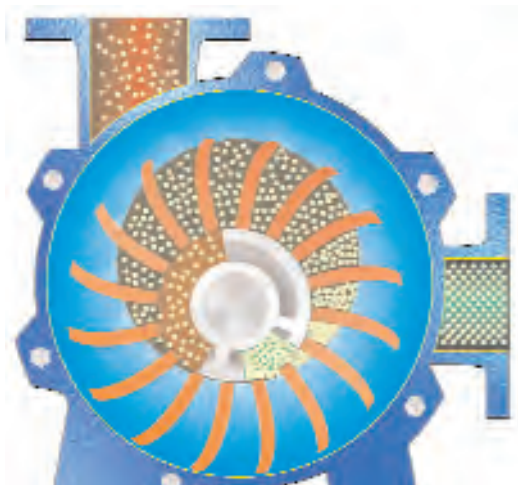

Reliable

- continuous operation
- increased operating efficiency
- reduced operating costs

One Moving Part

- reduced downtime in harsh operating conditions or locations
- reduced maintenance costs

High Volume Solids Recovery

- removal of liquid contaminants from the cake without danger to the air/gas handling equipment
- fractionated filtrate flows

Various Materials of Construction

- to satisfy many industrial application requirements

Other NASH Products

2BE3/P2620

Large liquid ring vacuum pumps with superior corrosion resistance
Top discharge capability which eliminates need for trench
Self-recirculating seal water, reducing need for external seal water source
Capacity of 4,000 to 23,000 CFM with vacuum to 24" HgV
Capacity of 6,800 to 39,000 m³/h with vacuum to 200 mbar abs



Vectra

Liquid ring vacuum pumps and compressors
Available in feature rich budget designs (XL or GL)
Designed to handle high back pressure requirements
Capacity of 115 to 2,860 CFM with vacuum to 29+ "HgV
Capacity of 195 to 4,860 m³/h with vacuum to 31 mbar abs



TC/TCM

Integral 2 stage liquid ring pumps with improved performance at vacuum levels down to 0.8" HgA (27 mbar)
Designed to handle large amounts of liquid carryover without difficulty
Capacity of 100 to 2,240 CFM with vacuum to 0.8" HgA
Capacity of 170 to 3,740 m³/h with vacuum to 27 mbar



Service

We have the know-how, the expertise and the specialists. We provide professional service to make your pumps run for decades. Our service centers are located in:

- Australia
- Brazil
- China
- France
- Germany
- Korea
- Netherlands
- Singapore
- South Africa
- Sweden
- UK
- USA



Compressors

Wide range of liquid ring compressors designed for many applications. Rugged and reliable, they can handle highly toxic, explosive and corrosive gases
Specifically developed for applications such as flare-gas, Chlorine and Vinyl Chlorine Monomer (VCM) recovery
Capacity of 60 to 2,200 SCFM with pressure to 200 PSIG
Capacity of 100 to 3,740 m³/h with pressure to 15 bar abs
Single and two stage models available



Gardner Denver Engineered Products Div.

9 Trefoil Drive
Trumbull, CT 06611 U.S.A.
phone: 203 459 3900
+1 800 553 NASH
fax: +1 203 459 3988
nash@gardnerdenver.com
www.GDNash.com

